



TECHNICAL SPECIFICATION

- ▶ **Body material:** Brass UNI EN 12165 CW617N (for 21A1K0R30-TXC; 21A2K0T12-XC; 21AN2K0T12-XC; 21A1ZT11D-GB)
- ▶ **Body material:** Brass UNI EN 12164 CW614N (for 4739MZU190; 4731K0T70; 4966K0Q120; 4592MZU190; 4966Z0Q120D)
- ▶ **Armature tube:** Stainless Steel AISI 300 series
- ▶ **Plungers:** Stainless Steel AISI 400 series
- ▶ **Spring:** Stainless Steel AISI 300 series
- ▶ **Piston:** POM C (for 4739MZU190; 4592MZU190)
- ▶ **Piston ring:** Modified PTFE (for 4739MZU190; 4592MZU190)
- ▶ **Main seal:** POM C=Acetalic resin (for 492MZU190; 4739MZU190) T=PTFE (for 4731K0T70); Q=PBT (for 4966K0Q120; 4966Z0Q120D)
- ▶ **Pilot seal:** TPU=Polyurethane resin (for 4739MZU190; 4592MZU190; 4966Z0Q120D); PTFE modified (for 4731K0T70; 4966K0Q120)
- ▶ **Seal:** RUBY (for 21A1K0R30-TXC); PTFE (for 21A1ZT11D-GB; 21A2K0T12-XC; 21AN2K0T12-XC)

- ▶ **Media:** water, steam, mineral oils, gas oil, fuel oils (for 21A1K0R30-TXC); air, inert gases (for 4739MZU190; 4592MZU190); air, water (for 21A2K0T12-XC; 21AN2K0T12-XC; 4731K0T70; 4966Z0Q120D; 4966K0Q120); air, water, steam, mineral oils (for 21A1ZT11D-GB)
- ▶ **Ambient temperature:** See coils catalogue page for its compatibility
- ▶ **Fluid temperature:** -40°C +180°C with RUBY, PTFE seals (for 21A1K0R30-TXC; 21A2K0T12-XC; 21AN2K0T12-XC) -10°C +100°C with POM C seals (for 4739MZU190; 4592MZU190) -40°C +98°C with PTFE seals (for 4731K0T70); -20°C +95°C with PBT seals (for 4966K0Q120; 4966Z0Q120D)
- ▶ **Design pressure PS:** 40 bar (for 21A1K0R30-TXC); PS: 50 bar (for 4739MZU190; 4592MZU190); PS: 100 bar (for 21A2K0T12-XC; 21AN2K0T12-XC; 4966K0Q120; 21A1ZT11D-GB); PS: 150 bar (for 4731K0T70); PS: 80 bar (for 4966Z0Q120D)
- ▶ **Protection class:** IP65 (complete with electric plug); IP67 (for 21AZT11D-GB);

- ▶ **Electrical conformity:** IEC 335
- ▶ **Switching time:** 20-40 msec (depending on pressure conditions)



Suffix description: ...(code)...-TXC

-TXC	Version with PTFE, rectified bridge
-TC	Version with rectified bridge
-GB	Version with dampness-proof

21A	1	K0	R	30	30	30
Model valve	1 SUBPLATE MOUNTING	K= N.C.	R= RUBY	Orefice 10 ⁻¹ mm	D for coil 8W	30
	2= G 1/4	Z= N.O.	U= POM C			
	3= G 3/8		T= PTFE			
	4= G 1/2		Q= PTB			
	5= G 3/4					

B	D	A	08	223	D	S
B= 30 mm Ø 13	D EN 175301-803	A= Class F	08= 8W	223= 220V-230V	D= AC	S= Without Approval
U= 36 mm Ø 13		V= Class H	12= 12W	112= 110V-120V	A= AC	Y= UL, CSA, VDE
G= 52 mm Ø 13			14= 14W	024= 24V	C= DC	

PIPE	Ø (mm)	Kv (l/min)	MAX VISCOSITY cSt (°E)	PRESSURE min	PRESSURE MAX MOPD (bar)						GAS CODE	NPT CODE	DRAWING REFERENCE
					COIL TYPE								
					AC			DC					
					B	U	G	B	U	G			

Normally Closed

SUBPLATE MOUNTING	3	4	53(7)	0	25	-	-	8	-	-	21A1K0R30-TXC		-
	19	-	-	1	-	-	-	-	-	50	4739MZU190 ⁽³⁾		1
G 1/4	1,2	1	12(2)	0	100	100	-	90	100	-	21A2K0T12-XC	21AN2K0T12-XC	-
G 3/8	7	14	12(2)	0,7 ⁽¹⁾	90	100	100	40	90	100	4731K0T70		3
G 1/2	12	60	12(2)	3	100	100	-	90	100	-	4966K0Q120		-
G 3/4	19	110	-	1	-	-	-	-	-	50	4592MZU190 ⁽³⁾		4

Normally Open

SUBPLATE MOUNTING	1,1	0,7	12(2)	0	90	-	-	90	-	-	21A1ZT11D-GB ⁽²⁾		-
G 1/2	12	60	12(2)	3	50	-	-	50	-	-	4966Z0Q120D		2

Note
- Pressure with mono frequency coil
- For dampness-proof cup see catalogue page
- Maximum allowed drop at 1 bar

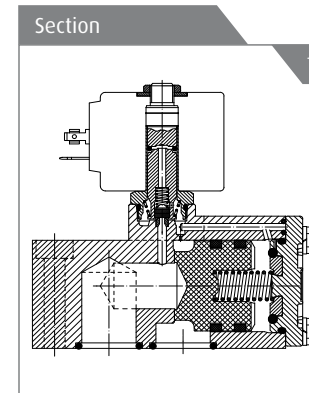

REPAIR KIT Normally Closed
Coil B type (8W)
KT130KR30-AP (for 21A1K0R30-TC)
KT130KT30-AP (for 21A2K0T12-XC; 21AN2K0T12-XC; 4731K0T70; for 4966K0Q120)

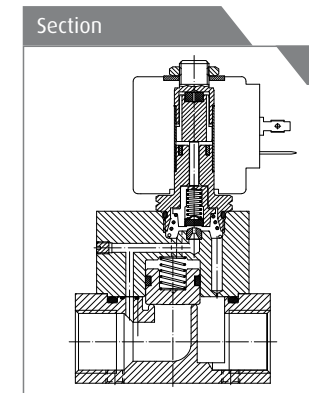

REPAIR KIT Normally Open
KT130ZT30-FGB (for 21A1ZT11D-GB)
KT130ZT30-F (for 4966Z0Q120D)

RELATED ITEMS

- ▶ P990305: Electrical plug EN 175301-803 Pg9
- ▶ P990306: Electrical plug EN 175301-803 Pg11
- ▶ P992126: Electrical plug EN 175301-803 Pg9 (with OR screw)
- ▶ P992127: Electrical plug EN 175301-803 Pg11 (with OR screw)
- ▶ P992128: Electrical plug EN 175301-803 cable 2 wires, 53cm
- ▶ R452714: Antihumidity kit (up to IP67 protection together with plugs P992126, P992127; P992128 & H coils class)
- ▶ P992087: Timer for automatic switch

INSTALLATION

- ▶ The solenoid valves can be mounted in any position
- ▶ Maintenance and instruction sheet available in each solenoid valve box
- ▶ Repair kit and coils available as spares

Drawing Reference

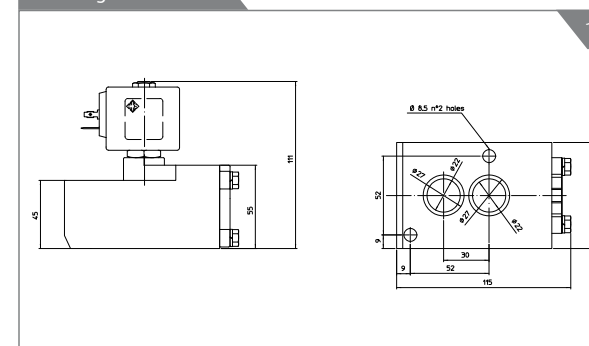

Drawing Reference

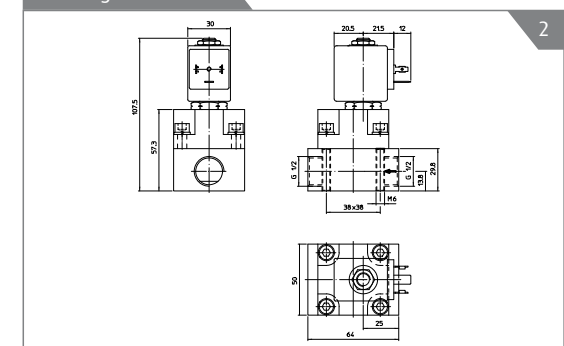

Dimensionale Table

Figure	Coil Type	D mm	E mm	F mm
1-2-3-4	B	30	42	54
	U	36	48	60
	G	52	55	67

