



Solenoid piston valve 2/2 way N.C. pilot control

4966K0Q120

PRESENTATION:

S.V. with pilot control for interception of fluids compatible of air and water.

A minimum operational pressure of 3 bar is required.

The materials used and the tests carried out ensure maximum reliability and duration.

USE: Automation

PIPES: G 1/2

COIL:

8W - Ø 13	
BDA - BSA	155°C (class F)
BDV	180°C (class H)
12W - Ø 13	
UDA	155°C (class F)
UDV	180°C (class H)

COIL HOUSING AND COIL FORMER MATERIAL ARE MADE BY 100% VIRGIN MATERIAL.

Max. allowable pressure (PS) 100 bar

Ambient temperature:

See coils catalogue page for its compatibility.



Gaskets	Temperature		Medium
	- 20°C	+95°C	
Q=PBT Glassfiber reinforced (Polibutilenterftalato)			Air, water

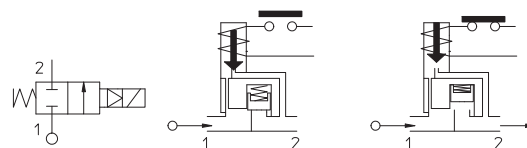

Pipe ISO 228/1	Code	Max viscosity		Ø mm	Kv l/mn	Power watt	Pressure		
		cSt	°E				min bar	M.O.P.D.	
								AC bar	DC bar
G 1/2	4966K0Q120	12	~ 2	12	60	8	3	100	90
						12			100

Note.

Available on request and with minimum quantities.

The "ODE" reserves the right to carry out technical and aesthetic modifications without prior notice.

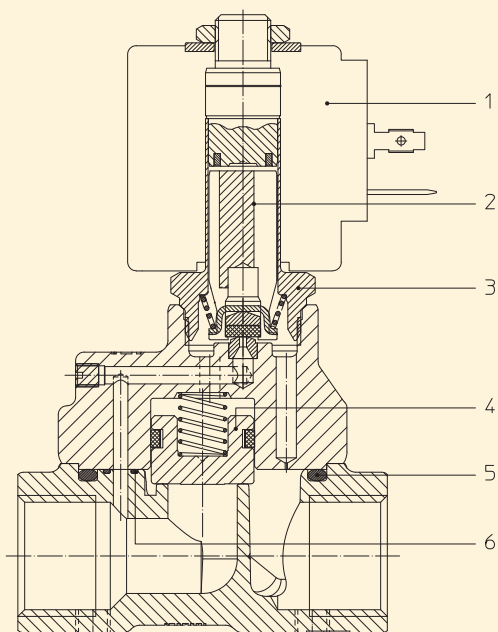
MATERIALS:

Body	Brass - UNI EN 12164 CW614N
Armature tube	Stainless steel AISI series 300
Fixed core	Stainless steel AISI series 400
Plunger	Stainless steel AISI seriea 400
Phase displacement ring	Copper - Cu 99,9%
Spring	Stainless steel AISI series 300
Piston Seal	PTFE modified
Main seal	Q=PBT
Orifice	Brass - UNI EN 12164 CW614N

On request:

Connector	Pg 9 o Pg 11
Connector conformity	ISO 4400

FEATURES:

Electrical conformity	IEC 335
Protection degree	IP 65 EN 60529 (DIN 40050) with coil fitted by connector.

SPARE PARTS:

1. Coil:	See coils list	KIT:
2. Complete plunger:	Code R450897	KT130K730-AP=2+3
3. Complete armature tube:	Code R450606	MAINTENANCE KIT:
4. Complete piston:	Code R452744	KTP4966K0Q12= 2+4+5+6
5. Gasket O-Ring:	Code R992130/B	
6. Gasket O-Ring:	Code R990382/B	

DIMENSIONS:
