



Solenoid valve 2/2 way N.C. Combined operation

21H11K0V120
÷
21H14K0V250-S

PRESENTATION:

Combined operation S.V. for interception of fluids compatible with the construction materials.
Minimum operational pressure is not required.
The materials used and the tests undertaken ensure maximum reliability and duration.

USE: Automation
Heating

PIPES: G 3/8 - G 1

COILS: 8W - Ø 13
BDA -BDS - BSA 155°C (class F)
BDP 160°C (high temperature)
BDF 180°C (class H)
SDH 155°C (class F)
12W -Ø 13
UDA 155°C (class F)
14W -Ø 13
GDH 180°C (class H)

MOULDING AND BOBBIN ARE MADE BY 100% VIRGIN MATERIAL.

Max. allowable pressure (PS)

G 3/8 - G 1/2 20 bar
G 3/4 - G 1 16 bar

Environment temperature:

with class **F** or high temperature coils - 10°C + 60°C
with class **H** coil - 10°C + 80°C



Gaskets	Temperature		Medium
	- 10°C	+140°C	
V =FKM (fluoroelastomer)	- 10°C	+140°C	Mineral oils (2°E), gasoline gas oil
B =NBR (nitrile rubber)	- 10°C	+ 90°C	Air, inert gas, water
E =EPDM (ethylene-propylene)	- 10°C	+140°C	Water, low pressure steam

For seals other than FKM replace the letter "V" with the ones corresponding to the other seals. E.I. 21H11K0**B**120.

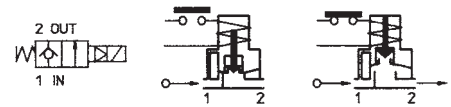

Pipe ISO 228/1	Code	Max viscosity		Ø mm	Kv (l/mn)	Power (watt)	Pressure			
		cSt	°E				min bar	M.O.P.D.		
								AC bar	DC bar	
G 3/8	21H11K0V120	12	~ 2	12	28	8	0	16	1,5	
						12		20	6	
						14		15	15	
G 1/2	21H12K0V120				19	70		8	5	-
								12	12	-
								14	15	-
G 3/4	21H13K0V190 *21H13K0V190-S			25	105	8	5	-		
						12	12	-		
						14	15	-		
G 1	21H14K0V250 *21H14K0V250-S	25	95	8	5	-				
				12	12	-				
				14	15	-				
								1	6	

Note

* For DC only.

The "ODE" reserves the right to carry out technical and aesthetic modifications without prior notification.

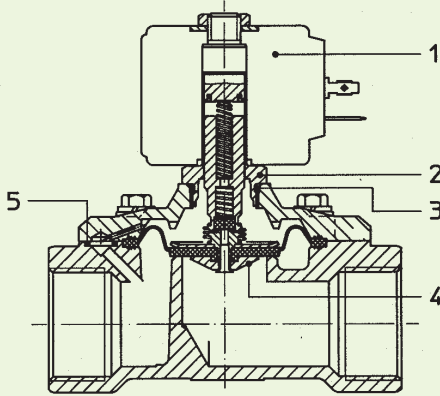
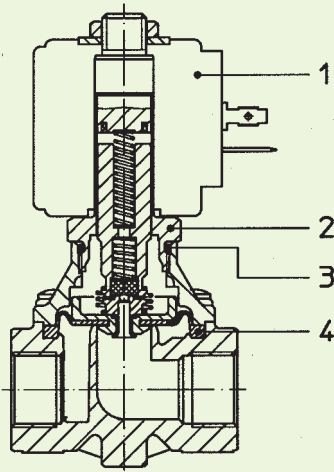

MATERIALS:

Body Brass - UNI EN 12165 CW617N
Welded armature tube Stainless steel AISI series 300
Fixed core Stainless steel AISI series 400
Plunger Stainless steel AISI series 400
Phase displacement ring Copper - Cu 99,9%
Spring Stainless steel AISI series 300
Seal Standard: V=FKM
 On request: B=NBR E=EPDM
Orifice Brass - UNI EN 12165 CW617

On request:
Connector Pg 9 or Pg 11
Connector conformity ISO 4400

FEATURES:

Electrical conformity IEC 335
Protection degree IP 65 EN 60529 (DIN 40050)
 with coil fitted by connector.

SPARE PARTS:

- 1. **Coil:**
See coils list
- 2. **Complete armature tube without gasket:**
Code R450603
- 3. **Gasket O-Ring :**
Code R990000/V
- 4. **Complete diaphragm with plunger:**
G 3/8 -G 1/2 Code R452127/V
G 3/4 -G 1 Code R452128/V
- 5. **Gasket O-Ring :**
G 3/4-G 1 Code R990002/V

MAINTENANCE KIT:

- G 3/8÷G 1/2
KTGH11K0V12=4
- G 3/4÷G 1
KTGH13K0V19=4+5

DIMENSIONS:

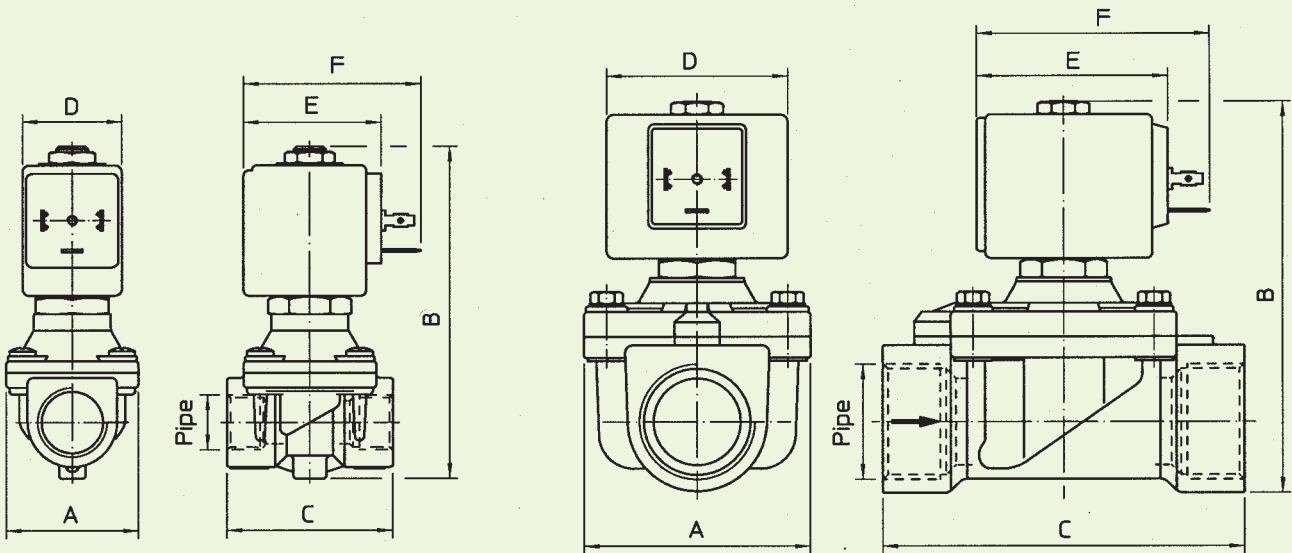

Type	Pipe ISO 228/1	A mm	B mm	C mm
21H11K0V120	G 3/8	40	100	50
21H12K0V120	G 1/2			
21H13K0V190	G 3/4	65	105	104
21H14K0V250	G 1		112	

COIL W ---	POWER ABSORPTION		TYPE	DIMENSIONS		
	Inrush VA~	Hold VA~		D mm	E mm	F mm
8 W	25	14,5	B	30	42	54
			S	32		
12 W	35	25	U	36	48	60
14 W	43	27	G	52	55	67