

TK-1



TK-1A



BIMETALLIC STEAM TRAP

GENERAL FEATURES

TK-1 Bimetallic Traps is operated by metal strips made of alloys with different coefficients of expansion that are bonded together.

At start-up, the trap is cold and the bimetallic element is relaxed. The valve is wide open. When steam enters the trap, it surrounds and heats the strips, which begin to expand at different rates. The element pulls directly on the valve stem, closing the valve against the pressure differential. As heat radiates from the trap, the strips begin to cool. When the element has cooled sufficiently, it relaxes and opens the valve.

TK-1 Bimetallic Traps, specially manufactured for **SUPER HEATED STEAM** applications. Appropriate isolation valves must be installed to ensure that maintenance and drainage are safe.

Installation

TK-1 can be installed both vertically and horizontally to the pipeline.

Applications

Trace Line
Driers
Press Units
Steam Jacketed Pipes
Convactor Heaters
Heaters
Steam Collectors
Condensate Pockets
Main Steam Line Ends
Super Heated Steam

WORKING CONDITIONS

Max. Pressure	40 bar
Max. Temperature	400 °C
Max. Differential Pressure	32 bar

*450°C opt. with gasket changes.

DIMENSIONS

Flanged - Threaded	Socket
DN15-DN50	DN15-DN25

CONNECTION TYPE

Threaded	NPT acc. to ANSI B1 20.1 BSP acc. to BS 21
Socket	ANSI B 16.11
Flanged	DIN 2635 (PN 40)



TK-1/TK1-A BIMETALLIC STEAM TRAP

THREADED CONNECTION

Discharge Capacities

(1/2" - 2")

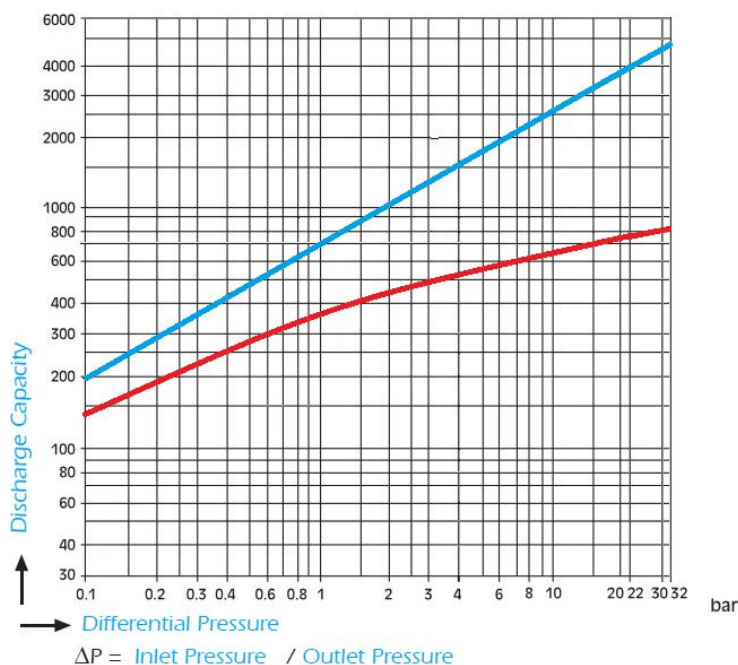

Red Chart

Δp = Condensate Discharge at the temperature which is max 10°C lower than steam saturation temperature.

Blue Chart

Δp = Cold Condensate Discharge at the temperature which is max 20°C lower than steam saturation temperature.

Black Chart

Δp = Cold Condensate Discharge at the temperature which is max 30°C lower than steam saturation temperature.

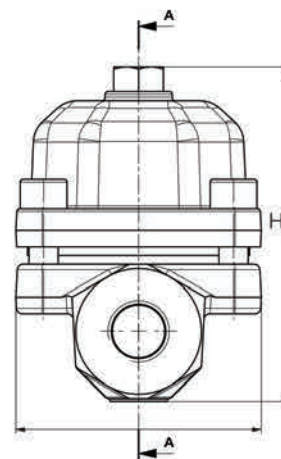
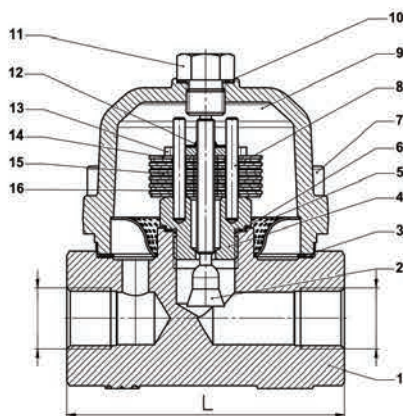
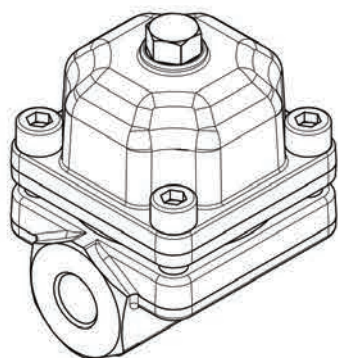

DN(mm)	H	L
15	114,5	95
20	114,5	95
25	114,5	95

TK-1/TK1-A BIMETALLIC STEAM TRAP

THREADED CONNECTION

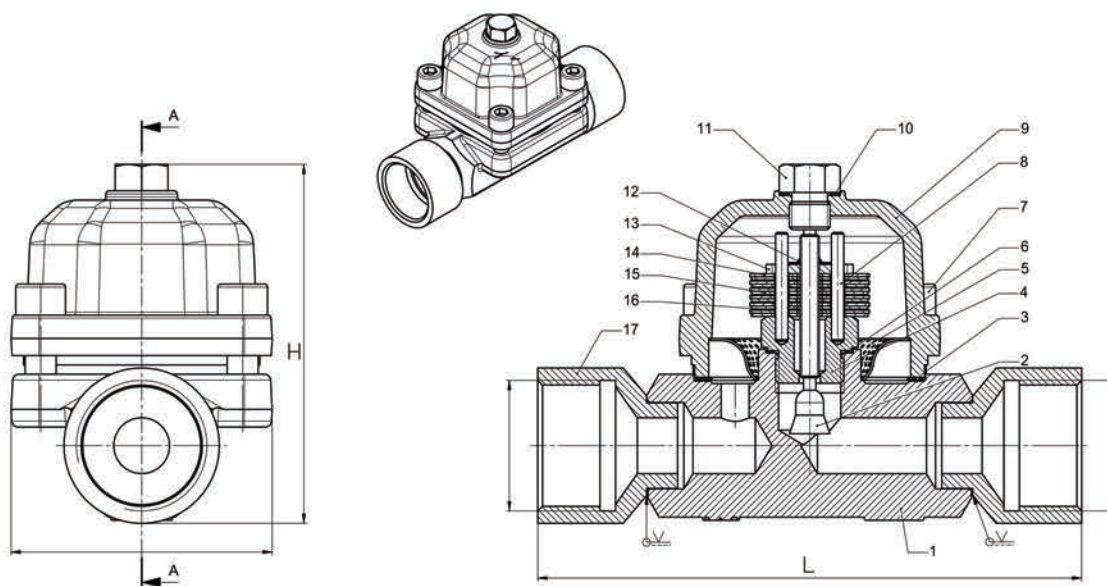

DN(mm)	H	L
32	115,5	175
40	121	185
50	125,5	195,5

PART LIST		
No	Part Name	Material
1	Body	C 22,8
2	Control Unit Seat	AISI 304
3	Gasket	Klingerit
4	Seat	AISI 304
5	Filter	AISI 304
6	Seat Gasket	AISI 304
7	Bolt	8,8
8	Bimetallic Plate Stem	AISI 304
9	Cover	C 22,8
10	Cover Set Gasket	AISI 304
11	Cover Set Stopper	9 SMn 36
12	Gasket Rove	AISI 304
13	Set Bolt Cushion	AISI 304
14	Bimetallic Plate	AISI 304
15	Bimetallic Plate	AISI 304
16	Bimetallic Plate Part	AISI 304
17	Threaded Reduction	9 SMn 36

TK-1/TK1-A BIMETALLIC STEAM TRAP

FLANGED CONNECTION

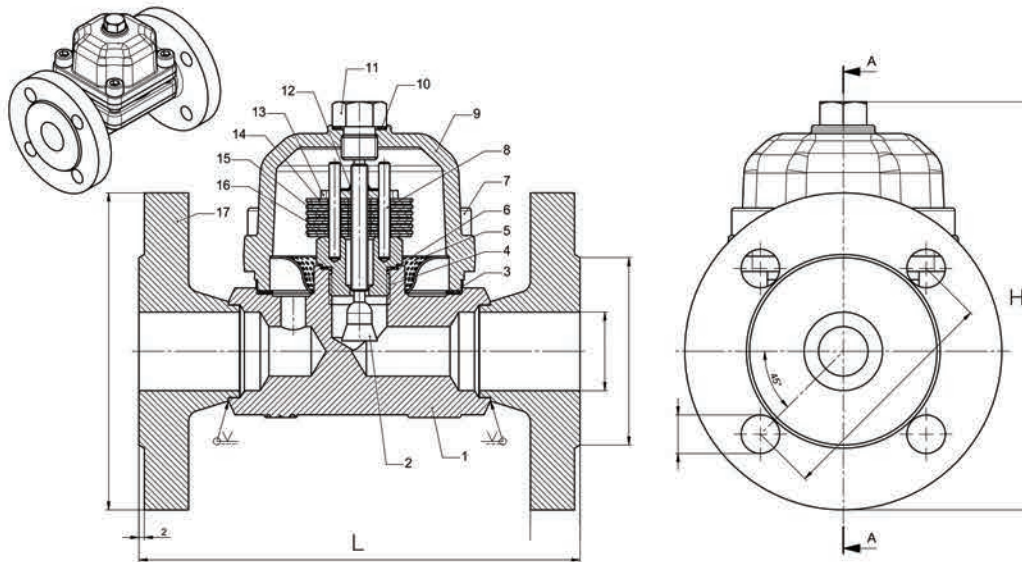

DN(mm)	H	L
15	114,5	138
20	114,5	143
25	114,5	148
32	115,5	160,5
40	121	165,5
50	125,5	173

PART LIST		
No	Part Name	Material
1	Body	C 22,8
2	Control Unit Seat	AISI 304
3	Gasket	Klingerit
4	Seat	AISI 304
5	Filter	AISI 304
6	Seat Gasket	AISI 304
7	Bolt	8,8
8	Bimetallic Plate Stem	AISI 304
9	Cover	C 22,8
10	Cover Set Gasket	AISI 304
11	Cover Set Stopper	9 SMn 36
12	Gasket Rove	AISI 304
13	Set Bolt Cushion	AISI 304
14	Bimetallic Plate	AISI 304
15	Bimetallic Plate	AISI 304
16	Bimetallic Plate Part	AISI 304
17	Flange	C 22,8
18	Adapter	C 1030

TK-1/TK1-A BIMETALLIC STEAM TRAP

SOCKET CONNECTION

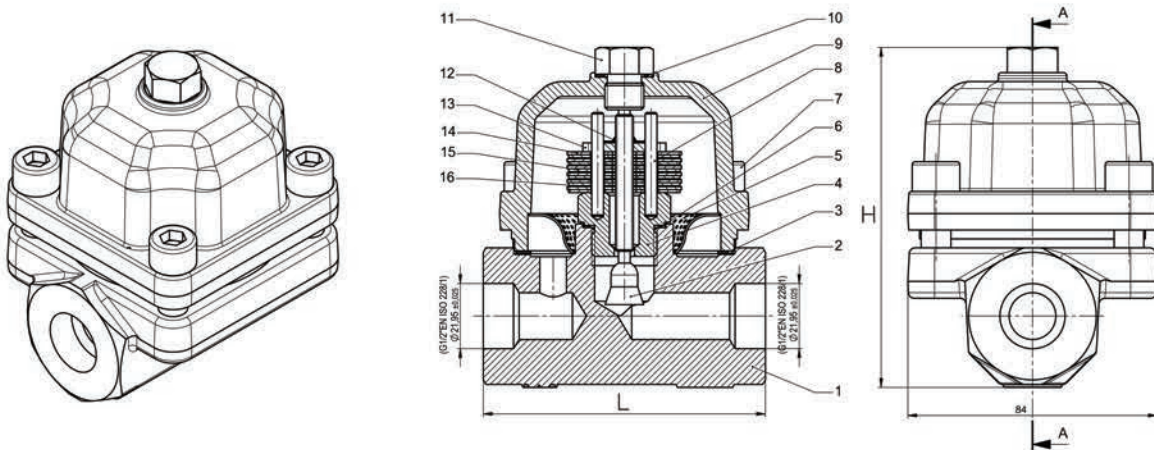

DN(mm)	H	L
15	114,5	95
20	114,5	95
25	114,5	95

PART LIST		
No	Part Name	Material
1	Body	C 22,8
2	Control Unit Seat	AISI 304
3	Gasket	Klingerit
4	Seat	AISI 304
5	Filter	AISI 304
6	Seat Gasket	AISI 304
7	Bolt	8,8
8	Bimetallic Plate Stem	AISI 304
9	Cover	C 22,8
10	Cover Set Gasket	AISI 304
11	Cover Set Stopper	9 SMn 36
12	Gasket Rove	AISI 304
13	Set Bolt Cushion	AISI 304
14	Bimetallic Plate	AISI 304
15	Bimetallic Plate	AISI 304
16	Bimetallic Plate Part	AISI 304

TK-1/TK1-A BIMETALLIC STEAM TRAP

SOCKET CONNECTION

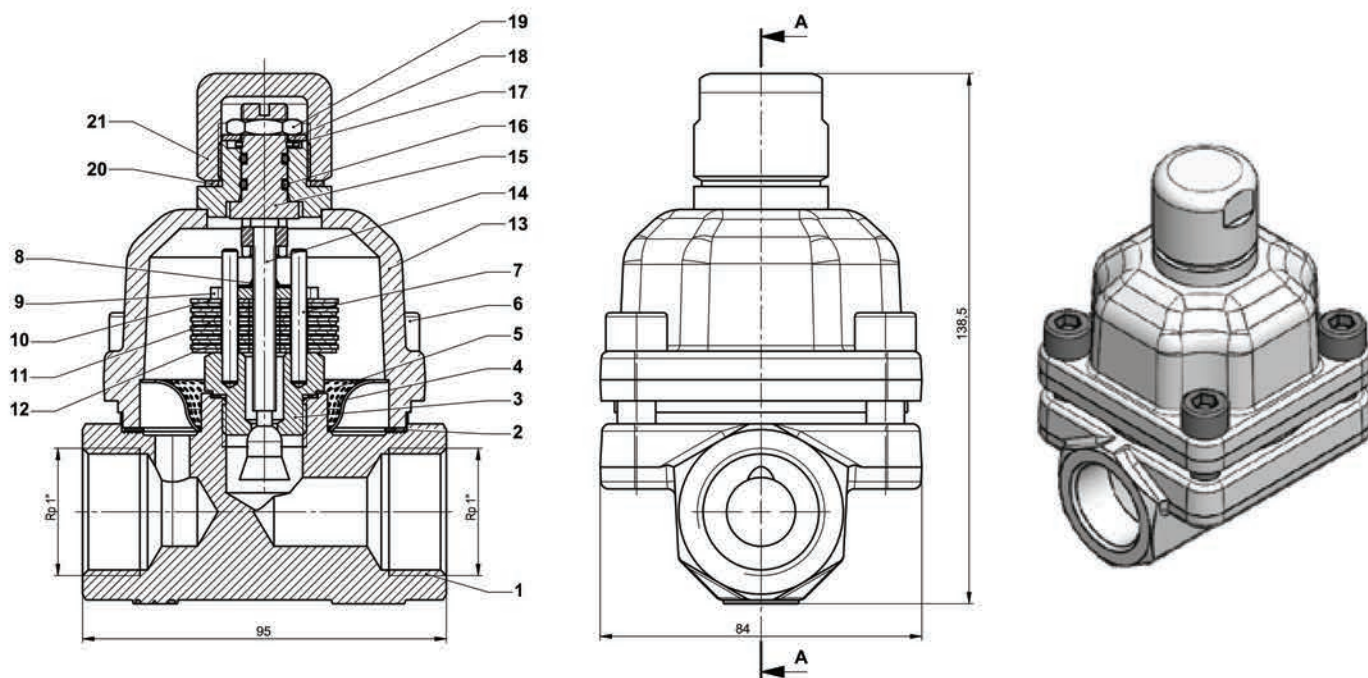

PART LIST		
No	Part Name	Material
1	Body	C 22,8
2	Gasket	Klingerit
3	Seat	AISI 304
4	Filter	AISI 304
5	Seat Gasket	AISI 304
6	Imbus Bolt	8,8
7	Bimetallic Plate Stem	AISI 304
8	Bolt Ring	AISI 304
9	Adjustment Nut Bearing	AISI 304
10	Bimetallic Plate	AISI 304
11	Bimetallic Plate	AISI 304
12	Bimetallic Plate	AISI 304
13	Cover & Seat Welding Connection	
14	Stem & Flap Welding Connection	AISI 304
15	Adjustment Bolt	AISI 304
16	O-ring	Viton
17	Bolt Ring	
18	Ring	1.0482
19	Nut	
20	Gasket	AISI 304
21	Adjustment Handle	1.0482

TK-1/TK1-A BIMETALLIC STEAM TRAP

SOCKET CONNECTION

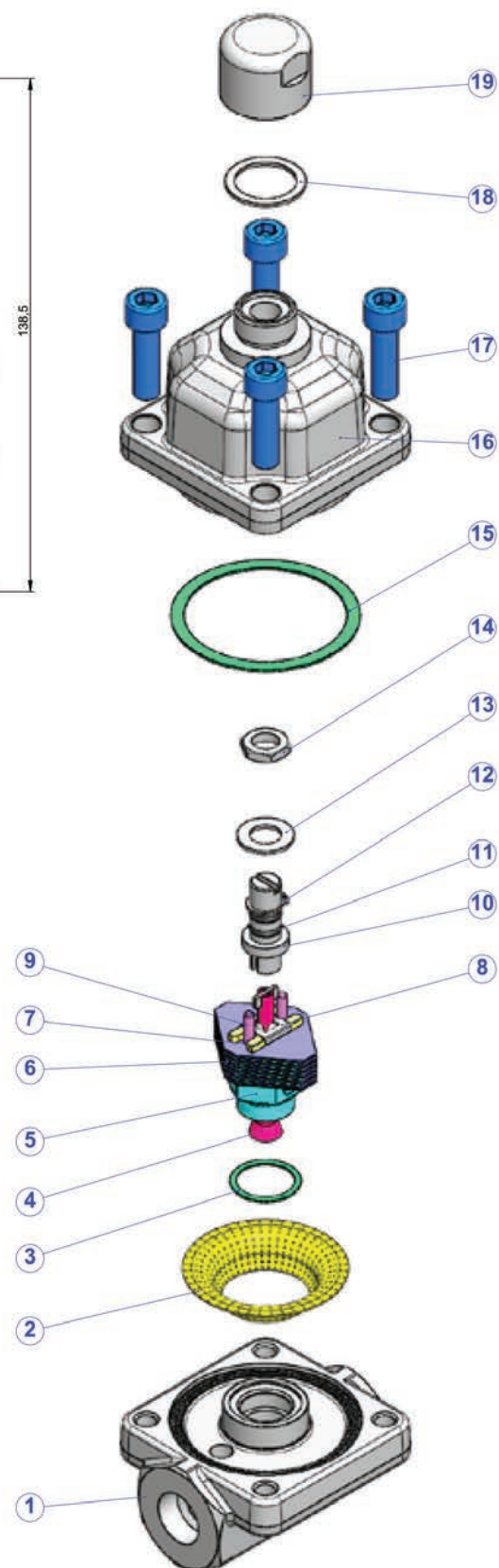
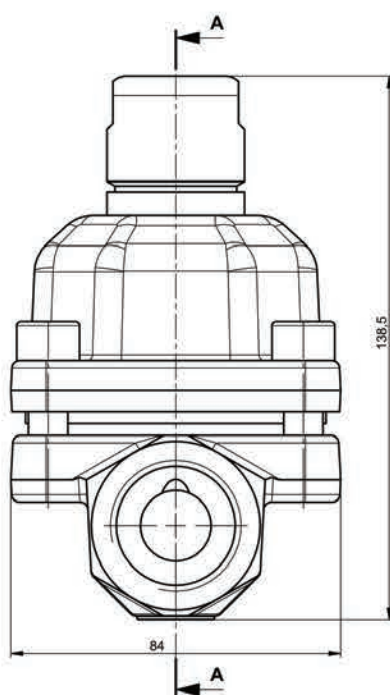
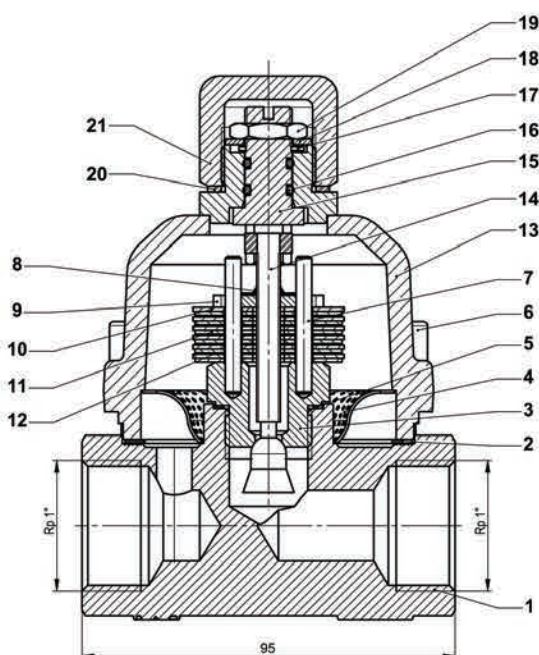

PART LIST		
No	Part Name	Material
1	Body	C 22,8
2	Gasket	Klingerit
3	Seat	AISI 304
4	Filter	AISI 304
5	Seat Gasket	AISI 304
6	Imbus Bolt	8,8
7	Bimetallic Plate Stem	AISI 304
8	Bolt Ring	AISI 304
9	Adjustment Nut Bearing	AISI 304
10	Bimetallic Plate	AISI 304
11	Bimetallic Plate	AISI 304
12	Bimetallic Plate	AISI 304
13	Cover & Seat Welding Connection	
14	Stem & Flap Welding Connection	AISI 304
15	Adjustment Bolt	AISI 304
16	O-ring	Viton
17	Bolt Ring	
18	Ring	1.0482
19	Nut	
20	Gasket	AISI 304
21	Adjustment Handle	1.0482

TK-1/TK1-A BIMETALLIC STEAM TRAP

SIDE VIEW



FRONT VIEW

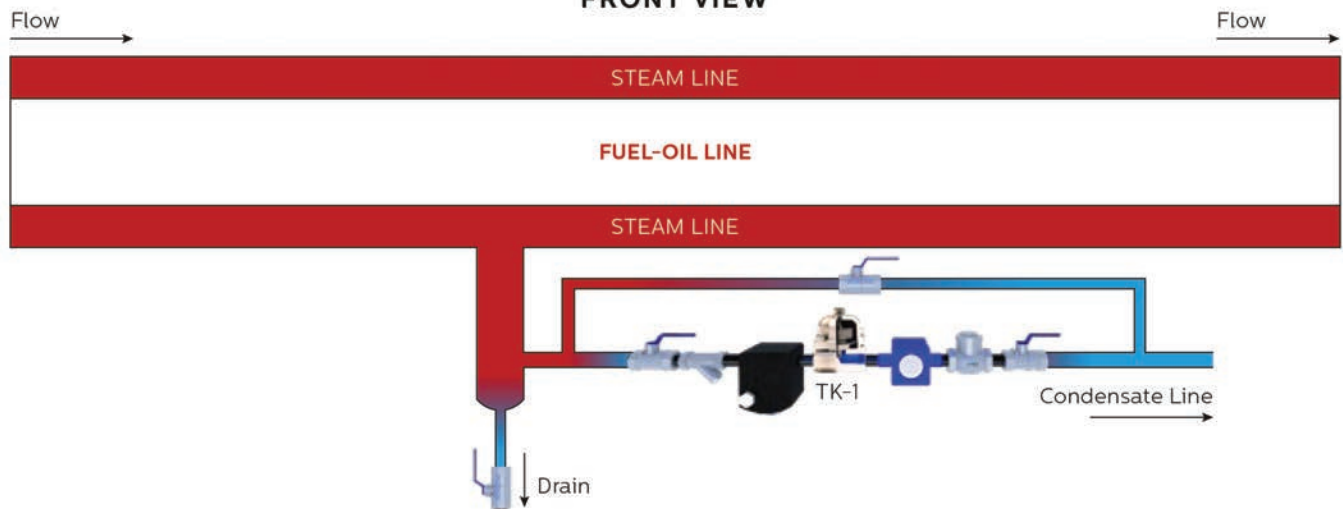

The thermal energy of the steam line is utilized to prevent heat loss in the fuel-oil line. Thus, heat loss in the fuel-oil line is prevented. Bimetallic steam trap is used in these lines due to the working principle. To benefit from the energy of the steam, bimetallic plates should be used to open at the lowest point of the saturated steam temperature.



HEAD OFFICE - FACTORY

Atatürk Sanayi Bölgesi Hadımköy Mahallesi Mustafa İnan Caddesi No: 44 Arnavutköy - İSTANBUL
 Tel: +90 212 771 01 45 (pbx) | Fax: +90 212 771 47 27
 info@ayvaz.com | www.ayvaz.com

**Cona
 Caserta/Italy**

Tel: +39 0823 187 3988
 rmolaro@ayvaz.com

**Ayvaz Germany
 Viernheim/Germany**

Tel: +49 62046014399
 germany@ayvaz.com

**Ayvaz Ukraine
 Kiev/Ukraine**

Tel: +380 44 390 57 57
 info@ayvaz.com.ua

**Tricorr
 Warsaw/Poland**

Tel: +48 530 030 810
 +48 533 603 335
 tricorr@tricorr.eu

**Ayvaz Azerbaijan
 Baku/Azerbaijan**

Tel: +99 (455) 579-84-32
 ahayatov@ayvaz.com

**Ayvaz Egypt
 Cairo/Egypt**

Tel: +20 122 819 78 29
 andrew.eid@ayvaz.com

**Ayvaz Gulf
 Dubai/U.A.E**

Tel: +971 563550822
 +971 501306871
 mideast@ayvaz.com

**Ayvaz China
 Ningbo/China**

Tel: +86 152 5830 7361
 msahin@ayvaz.com

**Ayvaz Kazakhstan LLP
 Almaty/Kazakhstan**

Tel: +7 (727) 327 97 57
 info_kz@ayvaz.com

Ayvaz N

İsperih/Bulgaria
 Tel: +359 8431 27 32
 office@ayvaz-n.eu

**Ayvaz Serbia
 Belgrade/Serbia**

Tel: +381 61 658 70 52
 yakbiyik@ayvaz.com

**Ayvaz Vietnam
 HCMC/Vietnam**

ggursoy@ayvaz.com
 Tel: +84 89 8508345

**Ayvaz Americas
 Rhode Island/USA**

Tel: +1 401 737 8380
 americas@ayvaz.com