

ARTICULO: 2225

Válvula de Aguja extremos roscados

Threaded ends Needle valve

Características	Features
1. Válvula de Aguja. 2. Construcción en acero inox. ASTM A479-04 (grado 316). 3. Extremos roscados hembra s/ ISO 228/1. 4. Presión máxima de trabajo 6000 psi a 38°C. 5. Temperatura de trabajo – 54 a 232 °C. 6. Dispositivo de seguridad del bonete para evitar desajuste. 7. Diseño del obturador con cierre posterior para proteger la estopada con válvula totalmente abierta	1. Needle valve. 2. Made of Stainless steel ASTM A479-04 (grade 316). 3. Threaded ends female acc. to ISO 228/1. 4. Max. Working pressure 6000 psi at 38°C. 5. Working Temperature – 54 to 232 °C. 6. Safety bonnet lock prevents accidental loosening. 7. Back seating design protects the packing in fully open position.

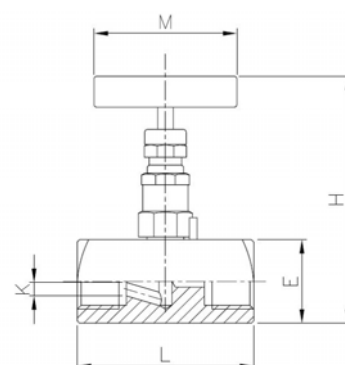
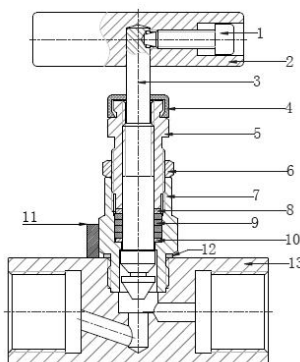

Nº	Denominación / Name	Material	Acabado Superficial / Surface Treatment
1	Tornillo de Fijación maneta / Grib Screw Handle	Acero Inoxidable 316 / S.S. 316	-----
2	Maneta / Handle	Acero Inoxidable 316 / S.S. 316	-----
3	Eje Obturador / Stem Shaft	Acero Inoxidable 316 / S.S. 316	Nitrurado Gaseoso / Nitrogen Treatment
4	Tapón protector / Dust Cap	Plastic	-----
5	Prensaestopas / Packing nut	Acero Inoxidable 316 / S.S. 316	-----
6	Tuerca prensaestopas / Lock Nut	Acero Inoxidable 316 / S.S. 316	-----
7	Bonete / Bonnet	Acero Inoxidable 316 / S.S. 316	-----
8	Arandela / Washer	Acero Inoxidable 316 / S.S. 316	-----
9	Estopada / Stem packing	PTFE + Grafito / PTFE + Graphite	-----
10	Arandela / Washer	Acero Inoxidable 316 / S.S. 316	-----
11	Perno Fijación / Lock Pin	Acero Inoxidable 316 / S.S. 316	-----
12	O'ring	FKM	-----
13	Cuerpo / Body	ASTM A479-04 (grado / grade 316)	

DIMENSIONES GENERALES / GENERAL DIMENSIONS

Ref	Medida / Size	PN (psi)	Dimensiones/Dimensions (mm)					PESO / WEIGHT (Kg)
			E	H	L	M	K	
2225 02	1/4"	6000	25.5	90	61	55	4	0,365
2225 03	3/8"	6000	25.5	90	61	55	4	0,355
2225 04	1/2"	6000	28.5	92	68	55	5	0,440
2225 05	3/4"	6000	38	98	76	55	6	0,800
2225 06	1"	6000	44.5	108	85	55	8	1,120

DIAGRAMA DE PÉRDIDAS DE CARGA / HEAD LOSSES DIAGRAM

(H₂O / 20 °C Flujo Horizontal / Horizontal flow).

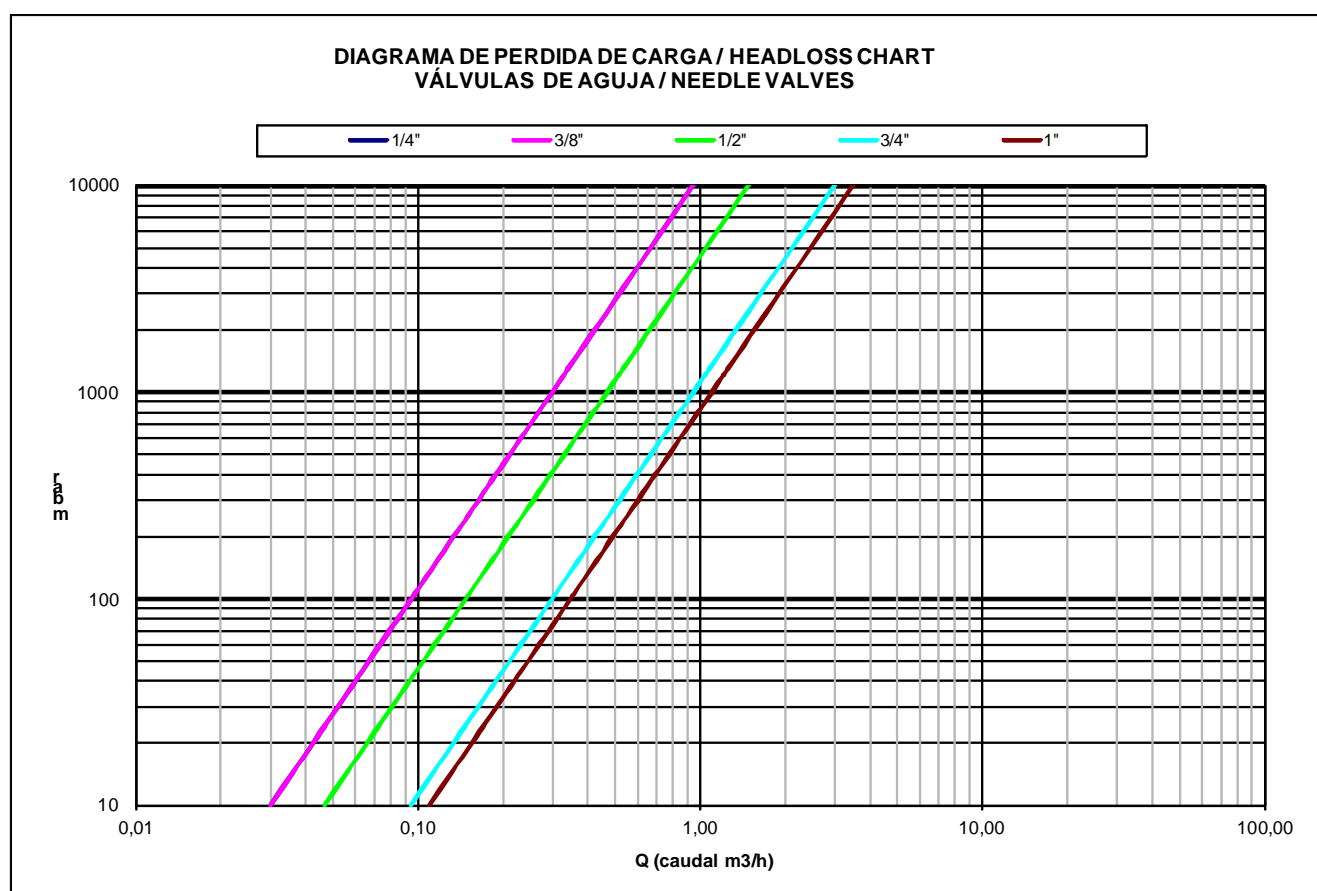

VALORES DE Kv / Kv VALUES

Kv = Es la cantidad de metros cúbicos por hora (m³/h) que pasará a través de la válvula generando una pérdida de carga de 1 bar.

Kv = Flow rate of water in cubic meter per hour (m³/h) that will generate a pressure drop of 1 bar across the valve.

Medida / Size	1/4"	3/8"	1/2"	3/4"	1"
m ³ /h	0.30	0.30	0.63	0.73	1.40

CURVA PRESIÓN TEMPERATURA / PRESSURE TEMPERATURE RATING

