

TOSACA

Model 1216 B

DESCRIPTION

Safety and relief valve, angle type, conventional
 Direct spring loaded
 Full lift safety valve
 Stainless steel, DUPLEX (on request)
 Steam, gases, cryogenic fluids, vapours and liquids
 Cleaned and degreased for oxygen service
 Flanges EN or ANSI
 PN16, PN 40, ANSI150 and ANSI300
 Seat metal- metal, Viton and PTFE
 Set pressure range 0,5 to 34,5 barg
 Tolerance Set pressure $\pm 3\%$
 Overpressure 10%
 European Pressure Equipment Directive PED 2014/68/EU
 CE 0056 Module B
 CE Production Quality Assurance (Module D) ES037955- 1035
 Material test certificate EN 10204 3.1



TOSACA, MADE IN SPAIN

MATERIALS

Item	Components	Material
1	Nozzle	A351 CF-3M
2	Body	A351 CF-3M
4	Cap	A351 CF-8
5 ^{SP}	Disc	AISI-316L
6	Guide	A351 CF-3M
7	Push Rod	AISI-316L
8	Spring Button	AISI-303
9	Ajusting Screw	AISI-303
10	Tensor Nut	AISI-303
11 ^{SP}	Spring	AISI-302
12	Lever	A351 CF-8
17	Release nut	AISI-304
18 ^{SP}	Lever axis	AISI-303
19	Packing lever axis	AISI-303
20 ^{SP}	Gasket cap	PTFE
21 ^{SP}	Gasket	PTFE
22 ^{SP}	Gasket pack. lever	Viton
28 ^{SP}	Soft seat	Viton / PTFE

^{SP} Recommended spare parts

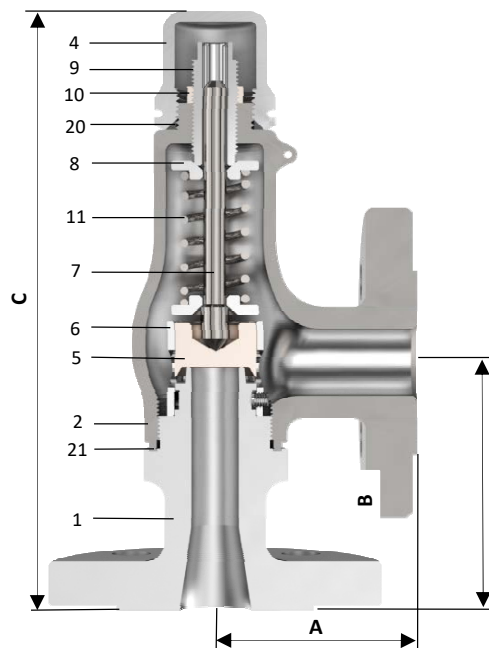

DIMENSIONS

	Connections		Orifice (mm)	Area (mm ²)	A (mm)	B (mm)	C (mm)	Weight (kg)
	Inlet	Outlet						
1/2" x 1"	ANSI150 or ANSI300	ANSI150	13	133	70	90	155	3
3/4" x 1"	ANSI150 or ANSI300	ANSI150	14	154	70	90	155	3,2
3/4" x 1"	ANSI150 or ANSI300	ANSI150	16	201	70	90	155	3,5
1/2" x 1"	ANSI150 or ANSI300	BSP/ NPT	13	133	45	90	155	3
3/4" x 1"	ANSI150 or ANSI300	BSP/ NPT	14	154	45	90	155	3,2
3/4" x 1"	ANSI150 or ANSI300	BSP/ NPT	16	201	45	90	155	3,5
15 x 25	PN 16 or PN 40	PN 16	13	133	70	90	155	3
20 x 25	PN 16 or PN 40	PN 16	14	154	70	90	155	3,2
25 x 25	PN 16 or PN 40	PN 16	16	201	70	90	155	3,5
15 x 1"	PN 16 or PN 40	BSP/ NPT	13	133	45	90	155	3
20 x 1"	PN 16 or PN 40	BSP/ NPT	14	154	45	90	155	3,2
25 x 1"	PN 16 or PN 40	BSP/ NPT	16	201	45	90	155	3,5

Version 2022

This data sheet can be subject to change without prior notice, for commercial use only